

FLEXMOUNT™ 8318

Installation Instructions

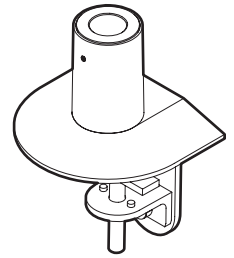

Desk Clamp

- 1
- 2
- 3

Thru-Desk

8318-cup

8318-thru

Wall Mount

- 1
- 2

* Hardware not included.

Reverse Wall Mount

8318-wall

- 1
- 2

* Hardware not included.

Grommet Hole

- 1
- 2
- 3

> 2.5"

Side Bolt



- 1
- 2

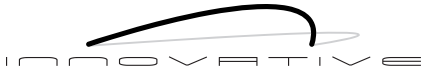



* Hardware not included.

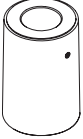
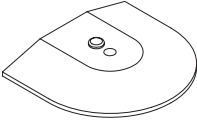
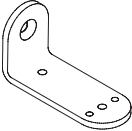
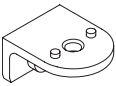
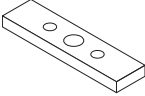
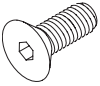

FLEXMOUNT™ 8318

Parts List

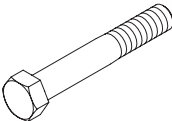
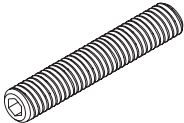
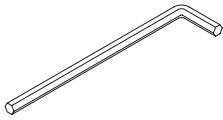
ITEM	DESCRIPTION / PART NO.	QUANTITY
A 	Mount Column 407602	1
B 	Base Plate 8321	1
C 	Large "L" Bracket 702828	1
D 	Small "L" Bracket 701116	1
E 	Rectangular Spacer 701544	1
F 	3/8-16 x 1-1/4" Flat Socket Cap Screw 701855	1
G 	3/8-16 x 7/8" Flat Socket Cap Screw 701799	1

ITEM	DESCRIPTION / PART NO.	QUANTITY
H 	3/8-16 Nylon Stop Nut 701418	1
I 	3/8-16 x 7/8" Button Socket Cap Screw 701122	1
J 	3/8-16 x 2-1/2" Hex Head Bolt 700268	1
K 	1/2-13 x 3" Socket Set Screw 701126	1
L 	7/32" Allen Wrench 701127	1
M 	3/32" Allen Wrench 700146	1

SWITCH™

Installation Instructions | Horizontal Positioning

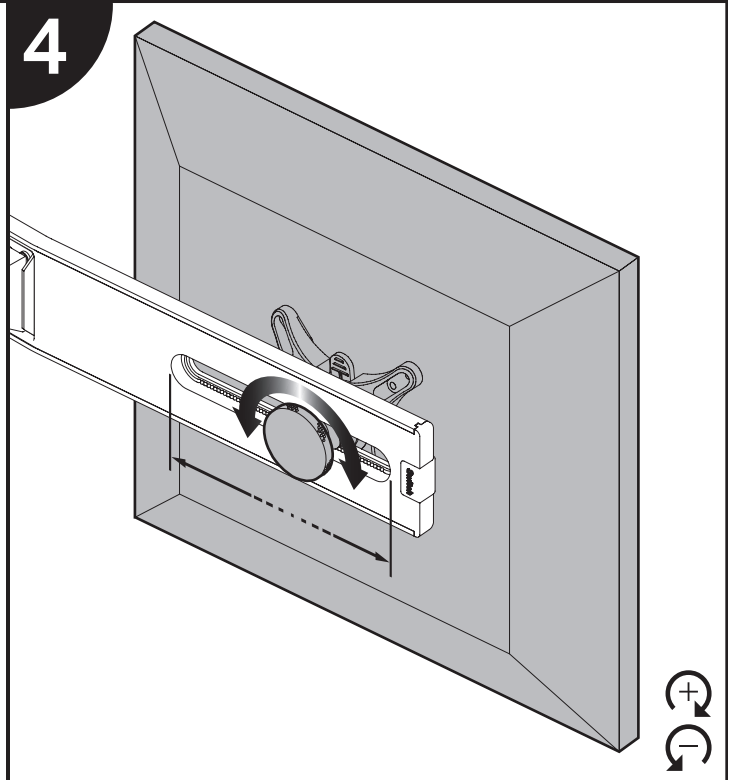
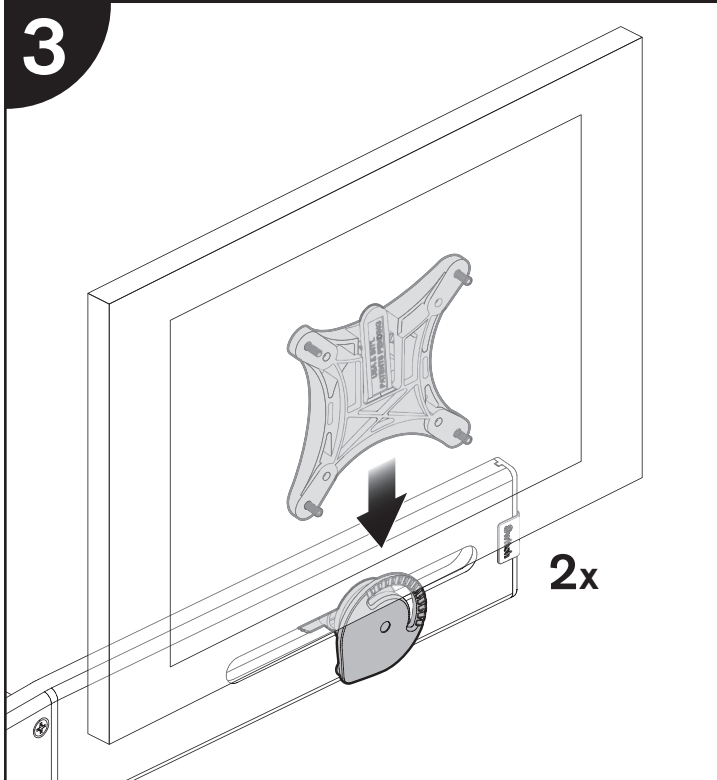
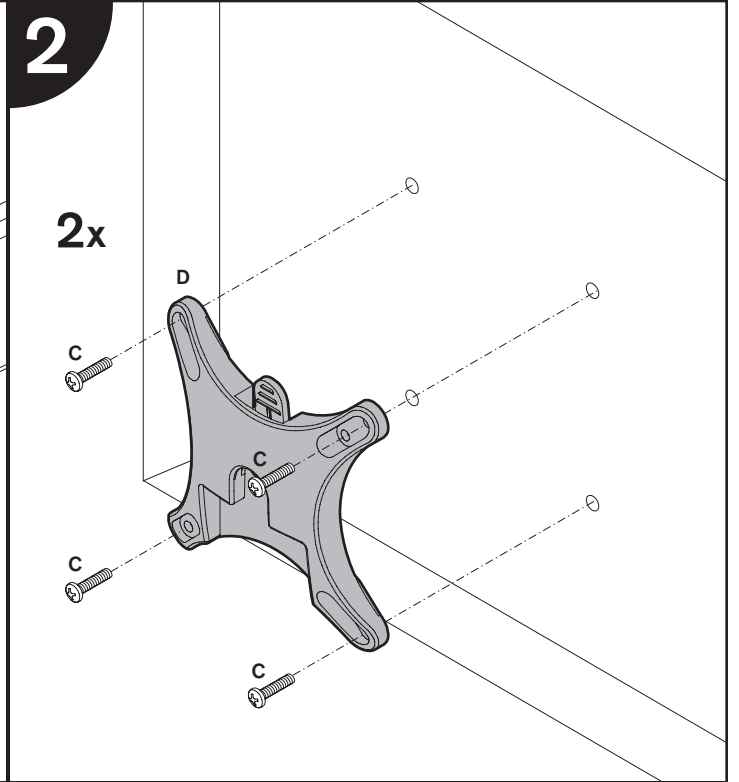
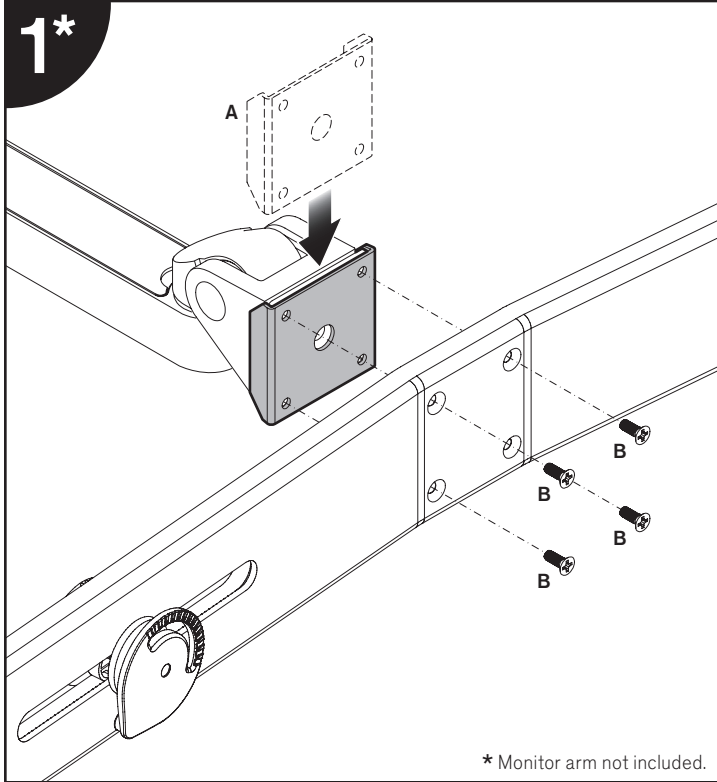
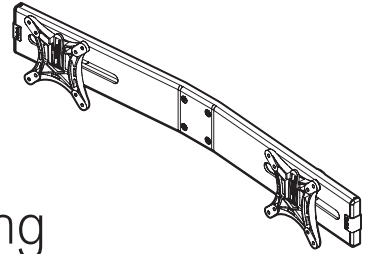

SWITCH™

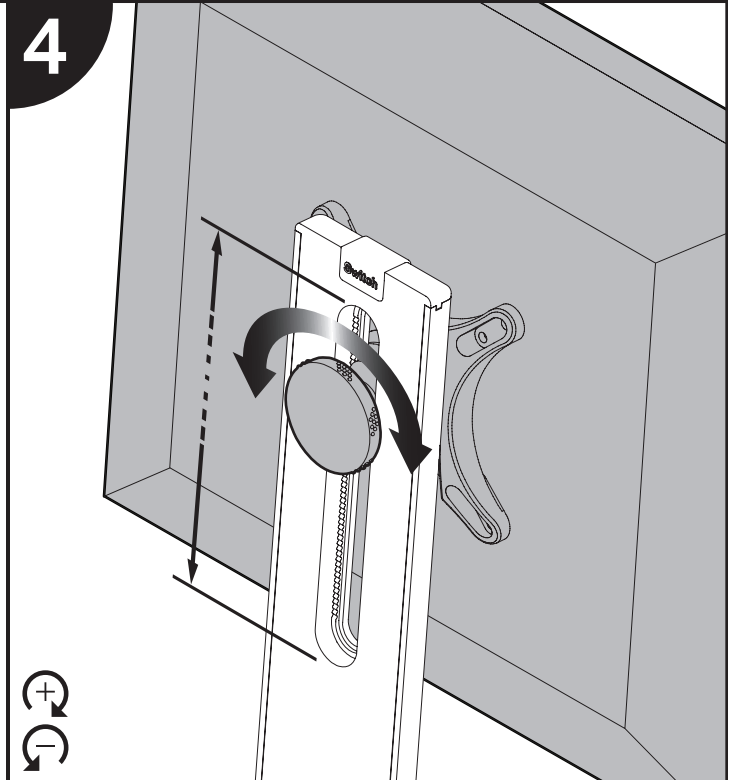
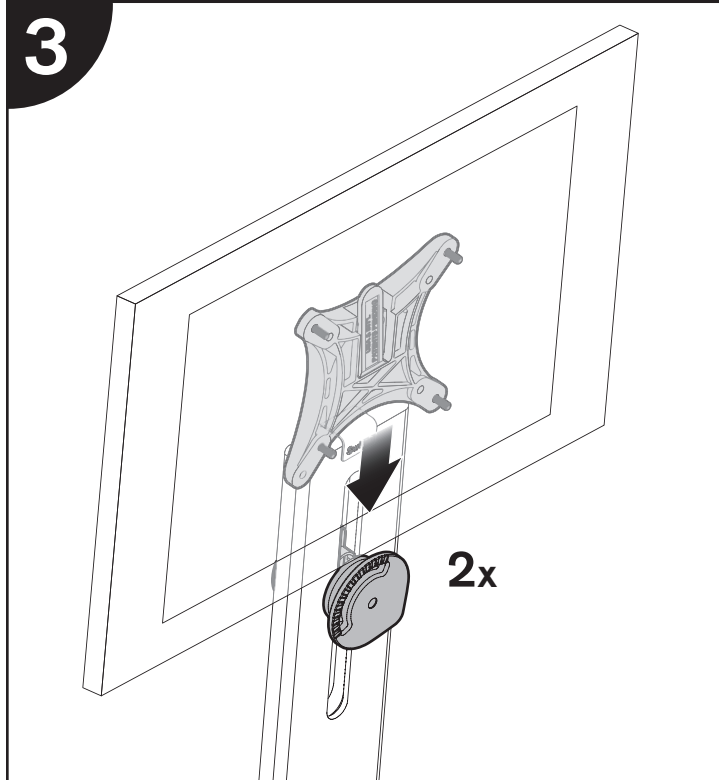
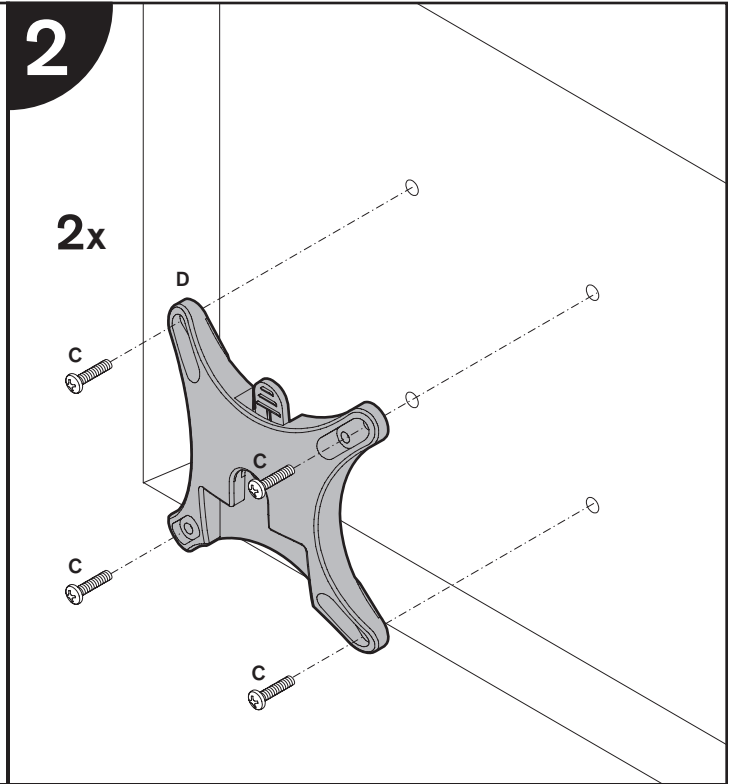
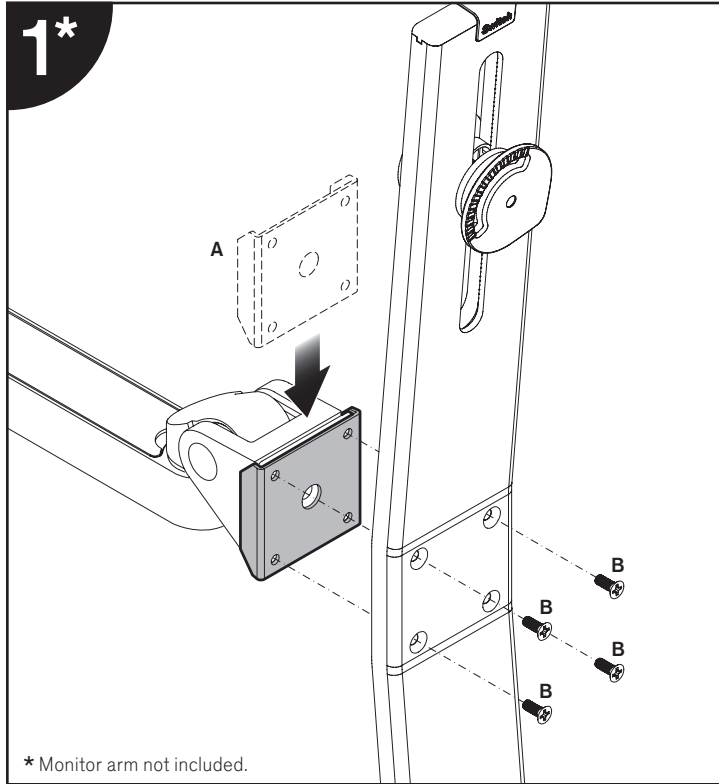

Installation Instructions | Vertical Positioning

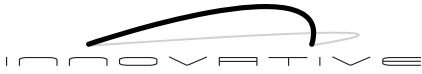

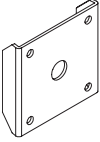

SWITCH™

Parts List

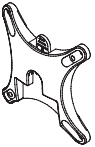
ITEM	DESCRIPTION / PART NO.	QUANTITY
A 	Rotation Prevention Bracket 106271	1
B 	10-32 x 1/2" FPhMS 709129	4
C 	M4 x 12mm Pan Head Screw 701153	8
D 	75/100mm VESA® Adapter 109464	2

MODEL 7500

Installation Instructions

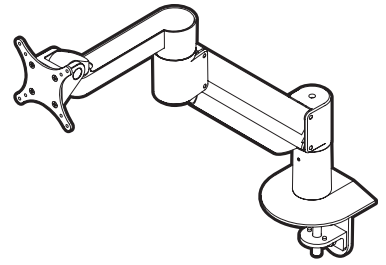

1

2

3

*Some monitors may require a spacer hardware kit. See page 2 for details.

4

5

6



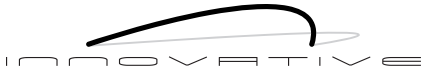

7



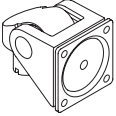
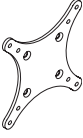

8

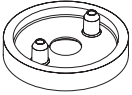

MODEL 7500

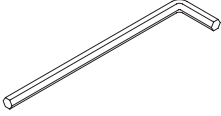
Parts List

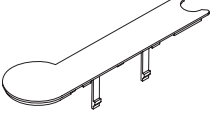
ITEM	DESCRIPTION / PART NO.	QUANTITY
A	 Spring-Assisted Monitor Tilter 407747	1
B	 75/100mm VESA® Adapter Plate 105587	1
C	 10-32 x 3/8" Phillips Flat Head Screw 702281	1 (4-pack)
D	 M4 x 12mm Phillips Pan Head Screw 702096	1 (4-pack)
E	 Dog Washer 105189	1
F	 10-32 x 3/8" FPHMS w/Lock Patch 705198	1

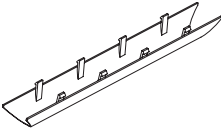
ITEM	DESCRIPTION / PART NO.	QUANTITY
G	 7/32" Allen Wrench 701127	1
H	 3/32" Allen Wrench 700146	1
I	 Forearm Cap 109597	1
J	 Endcap Bumper 702829	1
K	 Cable Cap 109344	1

OPTIONAL SPACER KITS In some cases, the mounting surface on your monitor may be recessed further than permitted by VESA® standards. As a result, a spacer kit may be required.

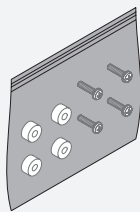
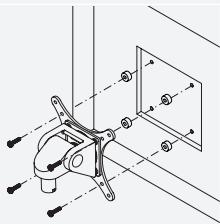

.25" Spacer Hardware Kit
 (4) .25" Spacers
 (4) M4 x 18mm Phillips Pan Head Screws
 Order # P404923-B

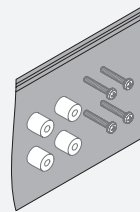

.5" Spacer Hardware Kit
 (4) .5" Spacers
 (4) M4 x 25mm Phillips Pan Head Screws
 Order # P404923-C