

THE KANGAROO ELITE

HORIZONTAL BAR ADJUSTMENT INSTRUCTIONS

If you have an offset weight on your Elite and want to move your main/larger monitor more in line with your eyes, by moving the entire horizontal bar left or right please follow the steps below.

Step 1: Start off by removing your monitors from the unit. Raise the unit to the standing position, tighten the brakes and slide the unit around to face the back side of the lifting assembly. Shown below.

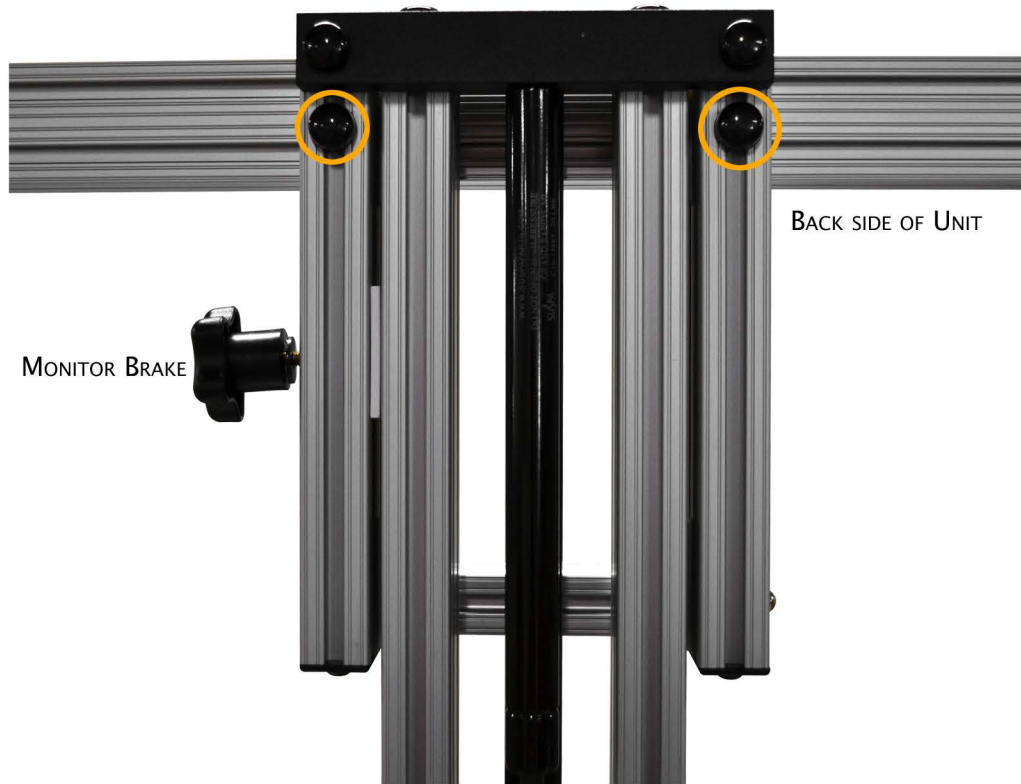

Step 2: Remove the two black plastic caps notated above with a set of pliers or a flat head screw driver.

Step 3: Loosen the two exposed bolts by only 1/2 to a full turn with a 7/16 wrench. **!!! DO NOT LOOSEN THE BOLTS FULLY, THEY WILL DISENGAGE FROM THE NUTS HOLDING THE HORIZONTAL BAR !!!**

Step 4: The Horizontal bar should now be able to slide left or right. We suggest putting the heaviest monitor in front of your eyes. Once you have the bar in the location you like, please tighten both loosened bolts from step 3. Once you have your monitors in position and mounted, make sure the unit is still sturdy.