

THE KANGAROO – ASSEMBLY INSTRUCTIONS

ASSEMBLY PARTS LIST

- A. (6) Black Screw Covers
- B. (2) 1/4–20 x 3.50 Hex Head Bolts
- C. (1) 5/32 Allen Wrench
- D. (2) Fender Washers
- E. (2) Acorn Nuts
- F. (3) 1/4–20 x 7/8 BHCS
- G. (2) Thick Black Washers
- H. (1) 7/16 Wrench
- I. (2) Locking Star Washers



Unit is shipped with (4) bolts and washers threaded into the monitor lifting assembly

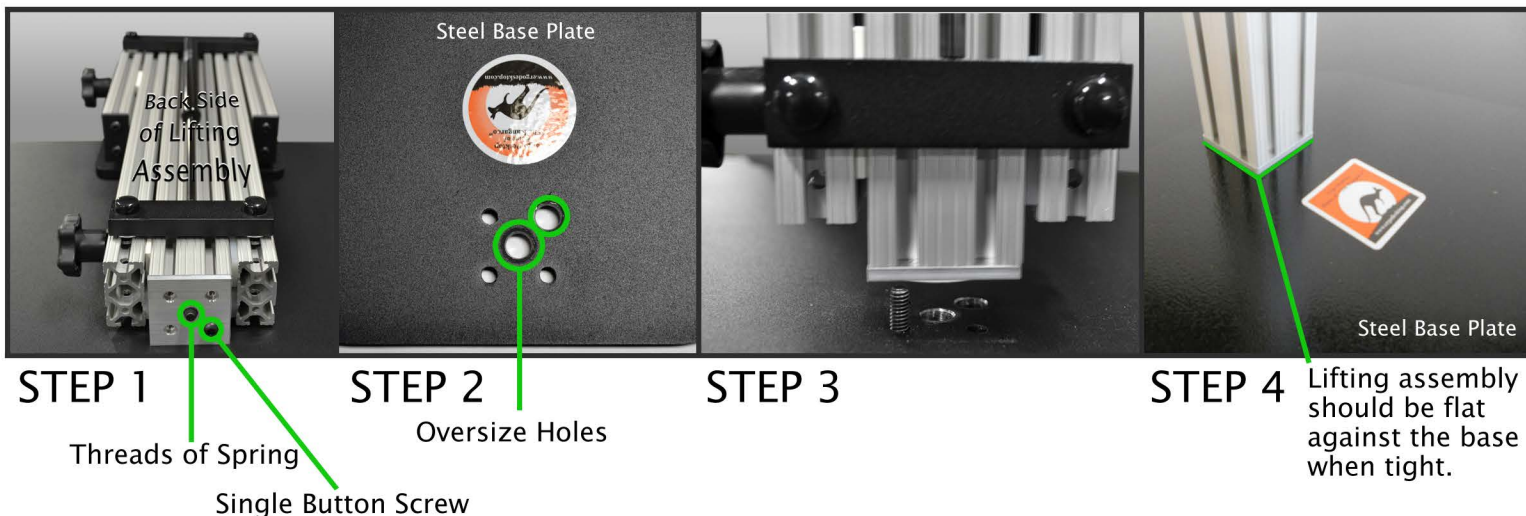

Step 1: Lay the lifting assembly on a solid surface with the back side up as shown. Notice the single Button Head Bolt and the Threads of the Spring in the assembly union. **DO NOT LOOSEN THE SINGLE BUTTON HEAD BOLT.**

Step 2: Now notice the (2) oversized holes in the Base Plate. The Single Button Head Bolt and the Threads of the Spring will go into these oversized holes.

Step 3: With the Base Plate over hanging the table about 2 inches, hold the Lifting Assembly above the Base Plate and align the Single Button Bolt and the Spring Threads into the oversized holes. Place one 1/4–20 x 7/8 BHCS through the base plate to screw in the lifting assembly.

Step 4: Insert and thread the other (2) 1/4–20 x 7/8 BHCS through the Base Plate and into the Lifting Assembly. Once all (3) bolts are threaded in, tighten securely with the 5/32 allen wrench. Lifting Assembly should be flat against the Base.

THE KANGAROO – ASSEMBLY INSTRUCTIONS

STEPS 5, 6, 7

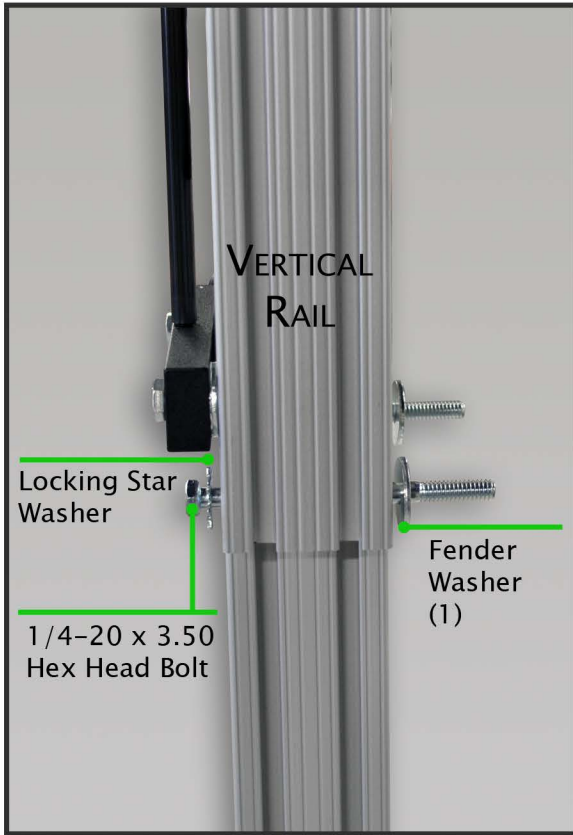

Step 5: Put (1) Locking Star Washer on each of the 1/4 -20 x 3.50 Hex Head Bolts.

Step 6: Insert the (2) 1/4-20 x 3.50 Hex Head Bolts through the holes in the Vertical Rail

Step 7: Put (1) Fender Washer on the each of the 1/4-20 x 3.50 Hex Head Bolts on the other side of the Vertical Rail.

STEP 9

Step 9: Put (1) Black Washer and (1) Acorn Nut on the end of each of the Hex Head Bolts. Using the 7/16 wrench tighten the Acorn Nuts securely.

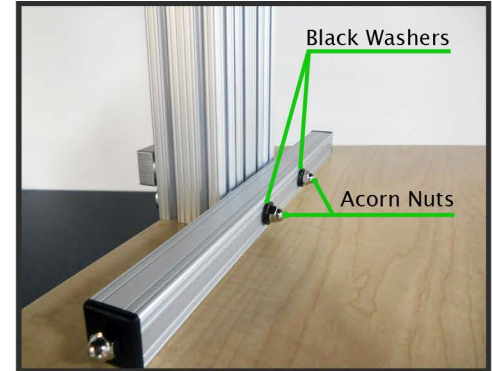

STEP 10

Step 10: Remove the (4) 1/4-20 x 1.0 hex head bolts and (4) washers from the bottom of the Monitor Lifting Assembly.

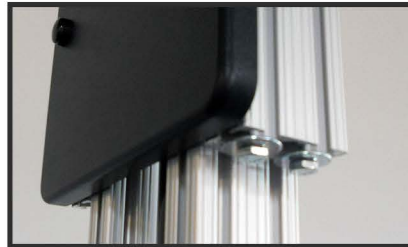

STEP 8

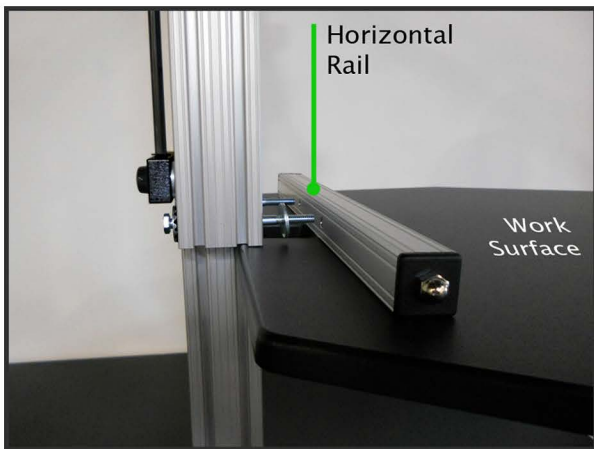

Step 8: Lift the Work Surface up and align the holes in the Horizontal Rail with the (2) 1/4-20 x 3.50 Hex Head Bolts. Push the Work Surface onto the Hex Head Bolts until the threads of the bolts come through the Horizontal Rail.

STEP 11, 12

Step 11: Position the Monitor Shelf below the lifting assemble and align the holes in the Monitor Shelf with the threaded holes in the Monitor Lifting Assembly.

Step 12: Thread the (4) hex head bolts into the threaded holes in the Monitor Lifting Assembly to secure the Monitor shelf to the unit. Tighten securely with a 7/16 wrench.

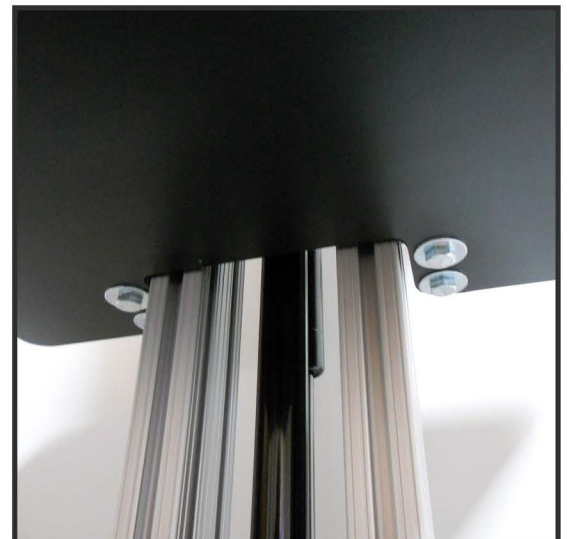

THE KANGAROO



Maximum Size LCD Monitor 24" and 15 lbs
Any questions about The Kangaroo
Contact us at info@ergodesktop.com

The Kangaroo is designed to hold your laptop or LCD monitor on the monitor shelf and your keyboard and mouse on the main work surface.

Your Kangaroo is shipped in the down position with both the monitor shelf brake and the main brakes tightened. The Kangaroo has (2) springs that assist in raising your unit to the standing position and work best when your laptop or monitor and keyboard are in place. This reduces the amount of pressure needed to lower the unit.

Always push down with both hands on the horizontal rear rail when lowering the main work surface.

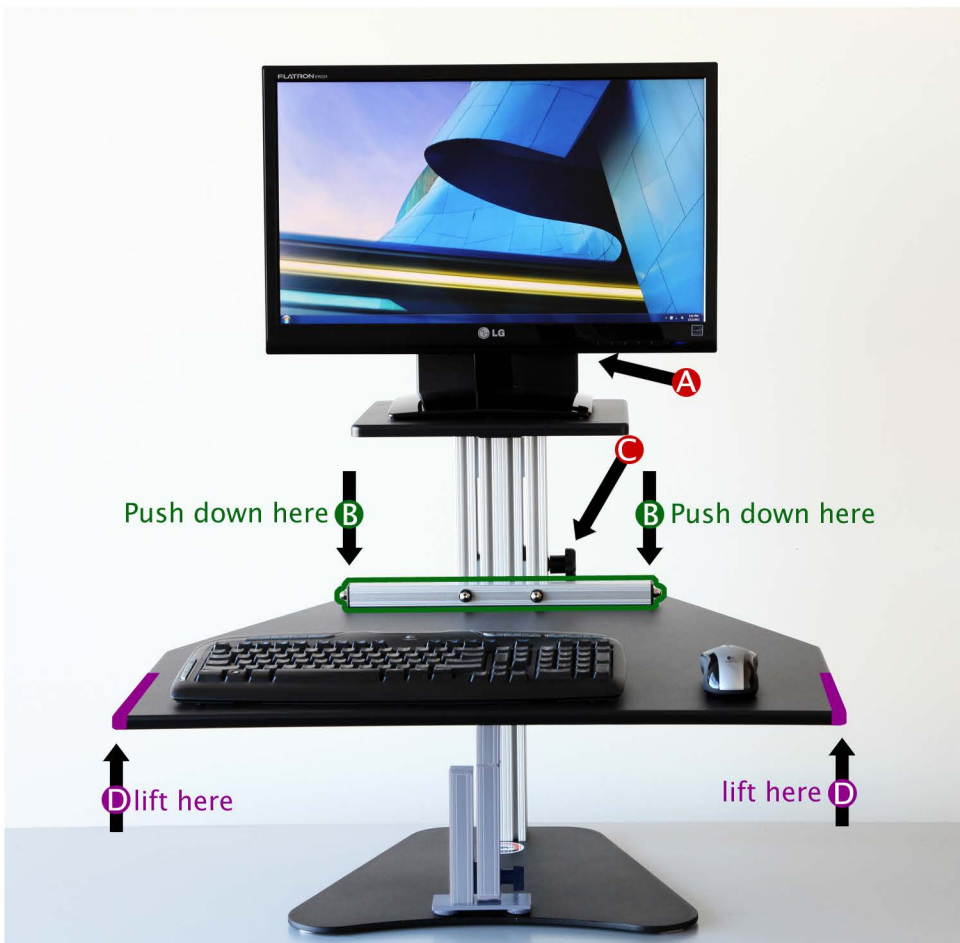

optimal location for support leg

HOW TO USE THE KANGAROO

To raise the Kangaroo, loosen the main brake(C) and lift the main work surface on the sides(D & D).

To raise the Monitor, loosen the monitor brake(A) and lift the monitor shelf.

To lower the Kangaroo, loosen the main brake(C) and lean into the unit using your upper body weight pushing down with both hands on the horizontal bar at the rear of the main horizontal work surface (B & B).

To Lower the monitor shelf, loosen the monitor brake(A) and push down with one or two hands on the monitor shelf.

A. Monitor Brake

B. Work Surface Rail

C. Main Brake

D. Main Work Surface



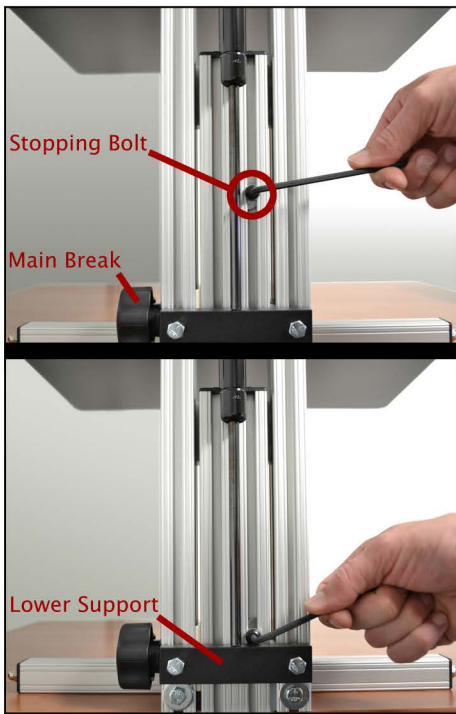

ADJUST STOPPING BOLT

On the back side of your unit you will notice a small bolt located on the lifting tower. This bolt is used as our work surface stopper. It is currently set at 15", the highest our unit should go. This setting is for a 6'2" user on a 30" high desk. If you are shorter than this, raise the unit to your desired height and tighten the Main Brake. Adjust the stopping bolt by loosening the bolt **with one turn** and drop the bolt down to reach the lower support, and re-tighten the stopping bolt.

If you are a taller individual and need to raise the stopping bolt, please note that the work surface can get up to 16 1/2 inches but you will be raising the unit into the oil dampening zone of the spring. This makes it a little more difficult to lower the unit into the seated position when raised to this maximum point.

Our work surface should only be raised to your belt or navel line. This creates a 90-110 degree angle in your elbows which is suggested in the standing position. This will also allow you to lower the unit with ease by simply transferring your upper body weight into the back of the unit.

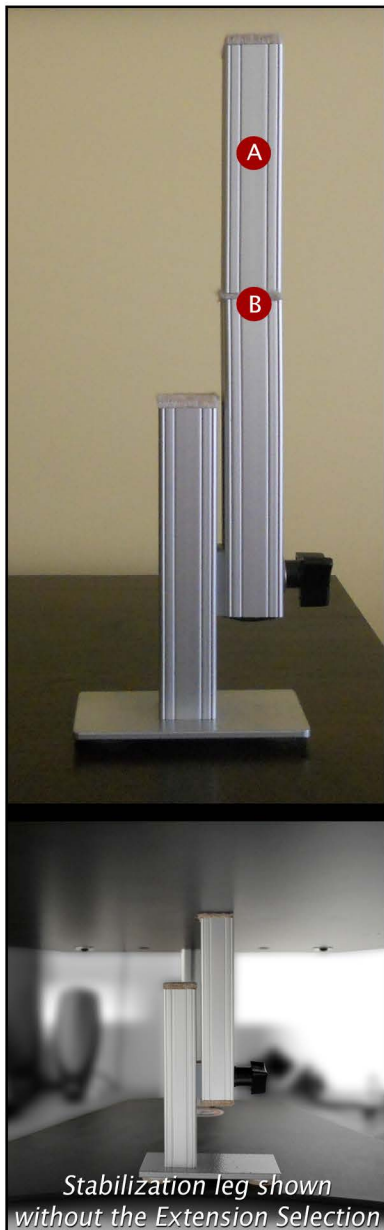

THE STABILIZATION LEG

Your adjustable height desk top unit comes with an adjustable leg that can be used to give you maximum stability when you are using "The Kangaroo" in the standing position.

Raise the Kangaroo work surface to your desired standing height and tighten the work surface brake.

Place the adjustable leg under the work surface and loosen the adjustable leg brake. Only loosen the brake by a turn or two, too much and the brake will disengage from the slot.

Extend the adjustable leg until it engages the bottom of the work surface and then tighten the adjustable leg brake.

The leg is shipped with the **extension section** installed to give you additional height adjustment. If this is too tall for your application, simply **unscrew the extension selection**.

A Extension Selection

B screws into here

ALWAYS REMOVE LEG BRACE BEFORE LOWERING THE WORK SURFACE.